

General English Language

Eng 121

Dr. Abderrahim JAMARI



King Faisal University

e- Learning Deanship

& Distance Education

First Class

English Language Basic English Grammar



In this lesson

- let's make sentences with the verb “be” (am, are, is).
- Sentence = SUBJECT + VERB.
- Subject = noun and pronoun (I, you, he, she, it , we, they ,this, these.)
- Subject + form of verb “be”



1-1 NOUN + IS + NOUN: SINGULAR

NOUN + IS + NOUN
(a) *Canada* is a *country*.

(b) Mexico is *a* country.

(c) *A* cat is *an* animal.

□ EXERCISE 3. Sentence practice.

Directions: Complete the sentences. Use an article (*a* or *an*).

1. A horse is an animal.
2. English is _____ language.
3. Tokyo is _____ city.

<i>animal</i>	<i>country</i>	<i>language</i>
<i>city</i>	<i>insect</i>	<i>sport</i>

1. Arabic is a language .
2. Rome is a city .
3. A cat is an animal .
4. Tennis is _____.
5. Chicago is _____.



1-2 NOUN + ARE + NOUN: PLURAL

NOUN + ARE + NOUN

(a) **Cats are animals.**

(b) SINGULAR: a cat, an animal

PLURAL: *cats, animals*

(c) SINGULAR: a city, a country

PLURAL: *cities, countries*

NOUN and NOUN + ARE + NOUN

(d) **Canada and China are countries.**

(e) **Dogs and cats are animals.**

□ EXERCISE 6. Sentence practice.

Directions: Change the singular sentences to plural sentences.

SINGULAR

PLURAL

1. An ant is an insect.

→

Ants are insects.

2. A computer is a machine.

→



1-3 PRONOUN + BE + NOUN

SINGULAR

PLURAL

PRONOUN + BE + NOUN

- (a) **I** **am** a student.
 (b) **You** **are** a student.
 (c) **She** **is** a student.
 (d) **He** **is** a student.
 (e) **It** **is** a country.

PRONOUN + BE + NOUN

- (f) **We** **are** students.
 (g) **You** **are** students.
 (h) **They** **are** students.

I }
you }
he } = pronouns
she }
it }
we }
they }

am }
is } = forms of *be*
are }

- (i) Rita is in my class. **She** is a student.
 (j) Tom is in my class. **He** is a student.
 (k) Rita and Tom are in my class. **They** are students.

I _____ .

Rita _____ .

Rita and Tom _____ .

You (*one person*) _____ .

You (*two persons*) _____ .



1-4 CONTRACTIONS WITH *BE*

	PRONOUN + <i>BE</i> → CONTRACTION			
AM	<i>I</i>	+ <i>am</i>	→ <i>I'm</i>	(a) <i>I'm</i> a student.
IS	<i>she</i>	+ <i>is</i>	→ <i>she's</i>	(b) <i>She's</i> a student.
	<i>he</i>	+ <i>is</i>	→ <i>he's</i>	(c) <i>He's</i> a student.
	<i>it</i>	+ <i>is</i>	→ <i>it's</i>	(d) <i>It's</i> a city.
ARE	<i>you</i>	+ <i>are</i>	→ <i>you're</i>	(e) <i>You're</i> a student.
	<i>we</i>	+ <i>are</i>	→ <i>we're</i>	(f) <i>We're</i> students.
	<i>they</i>	+ <i>are</i>	→ <i>they're</i>	(g) <i>They're</i> students.

1. *Sara* is a student. *She's* in my class.
2. *Jim* is a student. _____ in my class.
3. I have *one brother*. _____ twenty years old.



1-5 NEGATIVE WITH BE

- (a) I **am not** a teacher.
- (b) You **are not** a teacher.
- (c) She **is not** a teacher.
- (d) He **is not** a teacher.
- (e) It **is not** a city.
- (f) We **are not** teachers.
- (g) You **are not** teachers.
- (h) They **are not** teachers.

CONTRACTIONS

- I'm **not**
- you're **not** / you **aren't**
- she's **not** / she **isn't**
- he's **not** / he **isn't**
- it's **not** / it **isn't**
- we're **not** / we **aren't**
- you're **not** / you **aren't**
- they're **not** / they **aren't**

Examples: Africa \ city . . . It \ continent

→ Africa isn't a city. It's a continent.

Baghdad and Chicago \ city . . . They \ continent

→ Baghdad and Chicago are cities. They aren't continents.

1. Canada \ country . . . It \ city



1-6 *BE* + ADJECTIVE

NOUN	+	<i>BE</i>	+	ADJECTIVE
(a) A ball		is		<i>round.</i>
(b) Balls		are		<i>round.</i>
(c) Mary		is		<i>intelligent.</i>
(d) Mary and Tom		are		<i>intelligent.</i>
PRONOUN	+	<i>BE</i>	+	ADJECTIVE
(e) I		am		<i>hungry.</i>
(f) She		is		<i>young.</i>
(g) They		are		<i>happy.</i>

1. I'm not sad. I 'm happy _____.
2. Mr. Thomas isn't rich. He _____.
3. My hair isn't long. It _____.



1-7 BE + A PLACE

- (a) Maria is *here*.
(b) Bob is *at the library*.

- (c) Maria is {
here.
there.
downstairs.
upstairs.
inside.
outside.
downtown.

- PREPOSITION + NOUN
- (d) Bob is {
at *the library.*
on *the bus.*
in *his room.*
at *work.*
next to *Maria.*



1-7 BE + A PLACE

The diagram shows six examples of prepositions using a cube and a ball:







- ON:** A ball is placed on top of a cube.
- ABOVE:** A ball is positioned above a cube, not touching it.
- IN:** A ball is inside a cube.
- UNDER:** A ball is positioned below a cube.
- NEXT TO:** A ball is placed to the right of a cube.
- BEHIND:** A ball is placed behind a cube.

SOME COMMON PREPOSITIONS

<i>above</i>	<i>between</i>	<i>next to</i>
<i>at</i>	<i>from</i>	<i>on</i>
<i>behind</i>	<i>in</i>	<i>under</i>

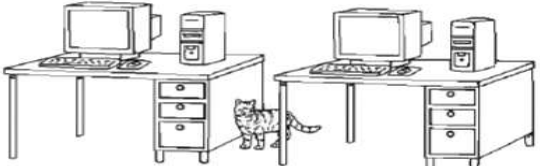

<i>above</i>	<i>between</i>	<i>next to</i>	<i>under</i>
<i>behind</i>	<i>✓ in</i>	<i>on</i>	

 <p>1. The cat is <u>in</u> the desk.</p>	 <p>2. The cat is _____ the desk.</p>
 <p>3. The cat is _____ the desk.</p>	 <p>4. The cat is _____ the desk.</p>
 <p>5. The cat is _____ the desk.</p>	 <p>6. The cat is _____ the desk.</p>
 <p>7. The cat is _____ the desks.</p>	



2-1 YES/NO QUESTIONS WITH *BE*

QUESTION	STATEMENT
<i>BE</i> + SUBJECT	SUBJECT + <i>BE</i>
(a) <i>Is Anna</i> a student?	<i>Anna is</i> a student.
(b) <i>Are they</i> at home?	<i>They are</i> at home.

1. A: Is Mrs. Lee a teacher?

B: Yes, Mrs. Lee is a teacher.

2. A: _____

B: Yes, the sun is a ball of fire.

3. A: _____

B: Yes, carrots are vegetables.



2-2 SHORT ANSWERS TO YES/NO QUESTIONS

QUESTION	SHORT ANSWER
(a) <i>Is Anna</i> a student?	→ Yes, <i>she is</i> . → No, <i>she's not</i> . → No, <i>she isn't</i> .
(b) <i>Are they</i> at home?	→ Yes, <i>they are</i> . → No, <i>they aren't</i> .
(c) <i>Are you</i> ready?	→ Yes, <i>I am</i> . → No, <i>I'm not</i> .*

A: _____ *Is Anna in your class?* _____





B: _____ *Yes, she is.* _____ (Anna is in my class.)

A: _____

B: _____ (I'm not homesick.)

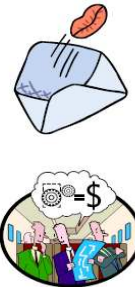

WH Questions Chart

Who?	What?	Where?	When?	Why?	How?
person people 	thing, idea, event or action 	place 	time 	reason 	manner, way 

Write more examples for each WH question.

1. Who is he?

2. What is this?

3. Where are you?

4. When is class?

5. Why is he scared?















6. How can we learn English?



Feelings Vocabulary

How do you feel?

I feel _____.

proud 	angry 
greedy 	excited 
sleepy 	happy 
thirsty 	hungry 
relaxed 	hurt 
confused 	sad 
loving 	worried 



How does he feel?



1. How does he feel - sleepy or happy?

He feels _____.



2. How does he feel - hungry or thirsty?

He feels _____.



3. How does he feel - confused or sleepy?

He feels _____.



2-4 USING *HAVE* AND *HAS*

SINGULAR	PLURAL	
(a) <i>I have</i> a pen.	(f) <i>We have</i> pens.	<i>I</i> } <i>you</i> } + <i>have</i> <i>we</i> } <i>they</i> }
(b) <i>You have</i> a pen.	(g) <i>You have</i> pens.	
(c) <i>She has</i> a pen.	(h) <i>They have</i> pens.	
(d) <i>He has</i> a pen.		<i>she</i> } <i>he</i> } + <i>has</i> <i>it</i> }
(e) <i>It has</i> blue ink.		

□ EXERCISE 9. Sentence practice.

Directions: Complete the sentences. Use *have* and *has*.

- We have grammar books.
- I _____ a dictionary.
- Kate _____ a blue pen. She _____ a blue notebook too.
- You _____ a pen in your pocket.
- Bob _____ a notebook on his desk.



Do your Homework on →



- Chapter 1: Exercise 3. page 2
- Ch. 1: Ex 4. page 3
- Ch. 1: Ex 6. page 4
- Ch. 1: Ex 10. page 7
- Ch. 1: Ex 12. page 8
- Ch 1: Ex 15. page 10
- Ch 1: Ex17. page 12
- Ch 1: Ex 25. page 19
- Ch2: Ex 2. page 25 + 26
- Ch 2: Ex 3. page 25 + 26
- Ch 2: Ex 9. page 30



Contact → If there is “a relevant question”.

Dr. Abderrahim JAMARI

Office Hours: 11:30 – 12:30 (Mon, Tue, wed)

Mobile :

Office Tel.

Email: aaljamari@kfu.edu.sa





بِسْمِ اللَّهِ الرَّحْمَنِ الرَّحِيمِ
بِحَمْدِ اللَّهِ

