

# ***General English Language***

**Eng 121**

**Instructor: Ammar Sultan Al-Maani**



**King Faisal University**

**e- Learning Deanship**

**& Distance Education**

# First Class

## English Language Basic English Grammar



# In this lesson

- let's make sentences with verb “be” (am, are, is).
- Sentences = SUBJECT + VERB.
- Subjects = nouns and pronouns (I, you, he, she, it , we, they ,this, these.
  
- Subject + form of verb “be”



## 1-1 NOUN + IS + NOUN: SINGULAR

NOUN + IS + NOUN  
(a) *Canada* is a *country*.

(b) Mexico is *a* country.

(c) *A* cat is *an* animal.

### □ EXERCISE 3. Sentence practice.

Directions: Complete the sentences. Use an article (*a* or *an*).

1.   A   horse is   an   animal.
2. English is \_\_\_\_\_ language.
3. Tokyo is \_\_\_\_\_ city.

<i>animal</i>	<i>country</i>	<i>language</i>
<i>city</i>	<i>insect</i>	<i>sport</i>

1. Arabic is   a language  .
2. Rome is   a city  .
3. A cat is   an animal  .
4. Tennis is \_\_\_\_\_.
5. Chicago is \_\_\_\_\_.



## 1-2 NOUN + ARE + NOUN: PLURAL

NOUN + ARE + NOUN

(a) **Cats are animals.**

(b) SINGULAR: a cat, an animal

PLURAL: *cats, animals*

(c) SINGULAR: a city, a country

PLURAL: *cities, countries*

NOUN and NOUN + ARE + NOUN

(d) **Canada and China are countries.**

(e) **Dogs and cats are animals.**

### □ EXERCISE 6. Sentence practice.

Directions: Change the singular sentences to plural sentences.

SINGULAR

PLURAL

1. An ant is an insect.

→

Ants are insects.

2. A computer is a machine.

→

\_\_\_\_\_



## 1-3 PRONOUN + *BE* + NOUN

### SINGULAR

### PLURAL

#### PRONOUN + *BE* + NOUN

#### PRONOUN + *BE* + NOUN

- (a) ***I***      ***am***      a student.  
 (b) ***You***    ***are***      a student.  
 (c) ***She***     ***is***        a student.  
 (d) ***He***      ***is***        a student.  
 (e) ***It***        ***is***        a country.

- (f) ***We***        ***are***      students.  
 (g) ***You***      ***are***      students.  
 (h) ***They***     ***are***      students.

*I*  
*you*  
*he*  
*she*  
*it*  
*we*  
*they* } = pronouns

*am*  
*is*  
*are* } = forms of *be*

- (i) Rita is in my class. ***She*** is a student.  
 (j) Tom is in my class. ***He*** is a student.  
 (k) Rita and Tom are in my class. ***They*** are students.

I \_\_\_\_\_ .

Rita \_\_\_\_\_ .

Rita and Tom \_\_\_\_\_ .

You (*one person*) \_\_\_\_\_ .

You (*two persons*) \_\_\_\_\_ .



## 1-4 CONTRACTIONS WITH *BE*

	PRONOUN + <i>BE</i> → CONTRACTION		
<b>AM</b>	<i>I</i>	+ <i>am</i>	→ <b><i>I'm</i></b> (a) <b><i>I'm</i></b> a student.
<b>IS</b>	<i>she</i>	+ <i>is</i>	→ <b><i>she's</i></b> (b) <b><i>She's</i></b> a student.
	<i>he</i>	+ <i>is</i>	→ <b><i>he's</i></b> (c) <b><i>He's</i></b> a student.
	<i>it</i>	+ <i>is</i>	→ <b><i>it's</i></b> (d) <b><i>It's</i></b> a city.
<b>ARE</b>	<i>you</i>	+ <i>are</i>	→ <b><i>you're</i></b> (e) <b><i>You're</i></b> a student.
	<i>we</i>	+ <i>are</i>	→ <b><i>we're</i></b> (f) <b><i>We're</i></b> students.
	<i>they</i>	+ <i>are</i>	→ <b><i>they're</i></b> (g) <b><i>They're</i></b> students.

1. *Sara* is a student.     *She's*     in my class.
2. *Jim* is a student. \_\_\_\_\_ in my class.
3. I have *one brother*. \_\_\_\_\_ twenty years old.



## 1-5 NEGATIVE WITH *BE*

- (a) I ***am not*** a teacher.
- (b) You ***are not*** a teacher.
- (c) She ***is not*** a teacher.
- (d) He ***is not*** a teacher.
- (e) It ***is not*** a city.
- (f) We ***are not*** teachers.
- (g) You ***are not*** teachers.
- (h) They ***are not*** teachers.

### CONTRACTIONS

- I'm not***
- you're not / you aren't***
- she's not / she isn't***
- he's not / he isn't***
- it's not / it isn't***
- we're not / we aren't***
- you're not / you aren't***
- they're not / they aren't***

*Examples:* Africa \ city . . . It \ continent

→ Africa isn't a city. It's a continent.

Baghdad and Chicago \ city . . . They \ continent

→ Baghdad and Chicago are cities. They aren't continents.

1. Canada \ country . . . It \ city





## 1-6 BE + ADJECTIVE

NOUN	+	BE	+	ADJECTIVE
(a) A ball		is		<b>round.</b>
(b) Balls		are		<b>round.</b>
(c) Mary		is		<b>intelligent.</b>
(d) Mary and Tom		are		<b>intelligent.</b>
PRONOUN	+	BE	+	ADJECTIVE
(e) I		am		<b>hungry.</b>
(f) She		is		<b>young.</b>
(g) They		are		<b>happy.</b>

1. I'm not sad. I 'm happy\_\_\_\_\_.
2. Mr. Thomas isn't rich. He \_\_\_\_\_.
3. My hair isn't long. It \_\_\_\_\_.



## 1-7 BE + A PLACE

- (a) Maria is *here*.  
(b) Bob is *at the library*.

- (c) Maria is { *here.*  
*there.*  
*downstairs.*  
*upstairs.*  
*inside.*  
*outside.*  
*downtown.*

- PREPOSITION + NOUN
- (d) Bob is { *at the library.*  
*on the bus.*  
*in his room.*  
*at work.*  
*next to Maria.*



# 1-7 BE + A PLACE

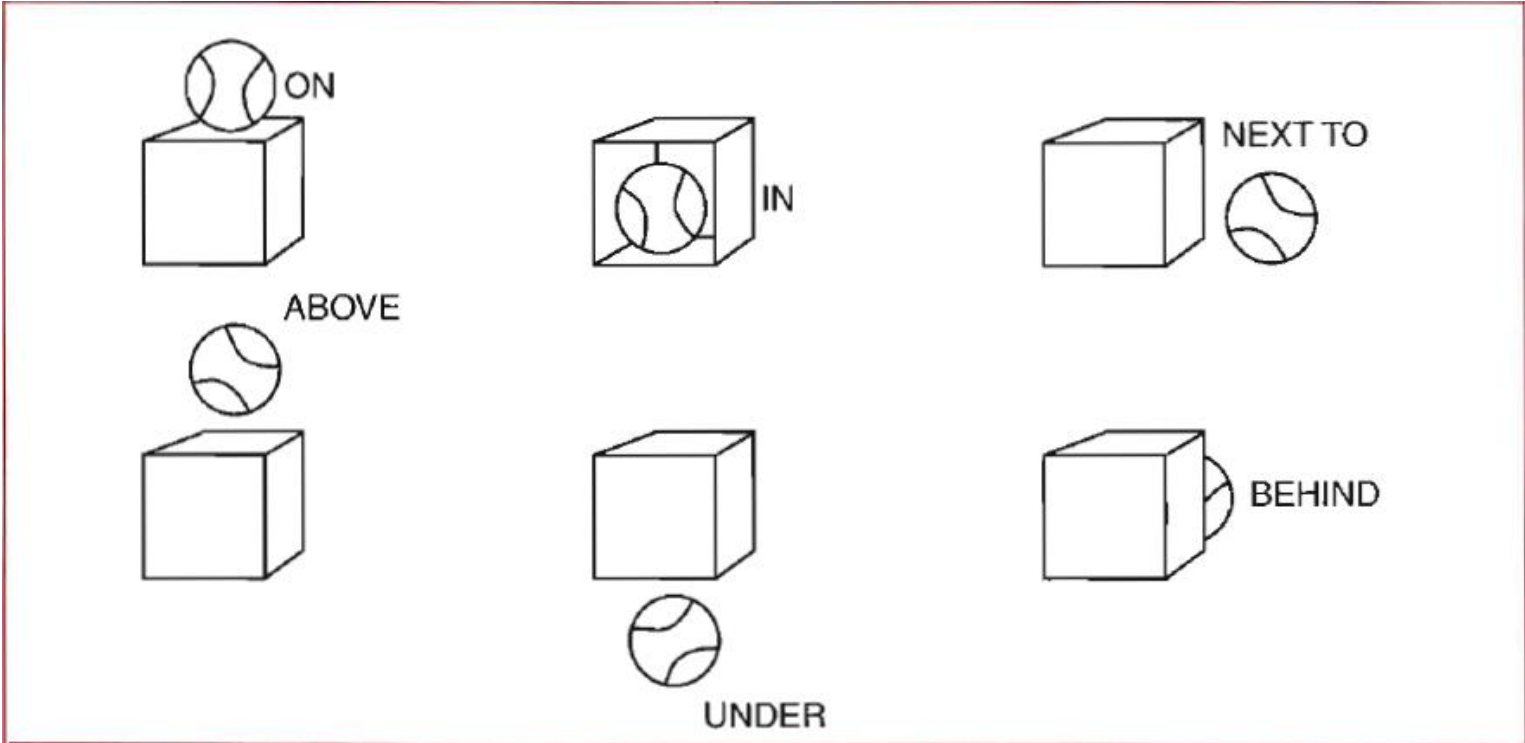







SOME COMMON PREPOSITIONS

<i>above</i>	<i>between</i>	<i>next to</i>
<i>at</i>	<i>from</i>	<i>on</i>
<i>behind</i>	<i>in</i>	<i>under</i>



above                      between                      next to                      under  
 behind                      ✓ in                      on

 <p>1. The cat is <u>in</u> the desk.</p>	 <p>2. The cat is _____ the desk.</p>
 <p>3. The cat is _____ the desk.</p>	 <p>4. The cat is _____ the desk.</p>
 <p>5. The cat is _____ the desk.</p>	 <p>6. The cat is _____ the desk.</p>
 <p>7. The cat is _____ the desks.</p>	



## 2-1 YES/NO QUESTIONS WITH *BE*

QUESTION	STATEMENT
<i>BE</i> + SUBJECT	SUBJECT + <i>BE</i>
(a) <i>Is Anna</i> a student?	<i>Anna is</i> a student.
(b) <i>Are they</i> at home?	<i>They are</i> at home.

1. A: \_\_\_\_\_ *Is Mrs. Lee a teacher?* \_\_\_\_\_

B: Yes, Mrs. Lee is a teacher.

2. A: \_\_\_\_\_

B: Yes, the sun is a ball of fire.

3. A: \_\_\_\_\_

B: Yes, carrots are vegetables.



## 2-2 SHORT ANSWERS TO YES/NO QUESTIONS

QUESTION	SHORT ANSWER
(a) <i>Is Anna</i> a student?	→ Yes, <i>she is</i> . → No, <i>she's not</i> . → No, <i>she isn't</i> .
(b) <i>Are they</i> at home?	→ Yes, <i>they are</i> . → No, <i>they aren't</i> .
(c) <i>Are you</i> ready?	→ Yes, <i>I am</i> . → No, <i>I'm not</i> .*

A: \_\_\_\_\_ *Is Anna in your class?*





B: \_\_\_\_\_ *Yes, she is.* (Anna is in my class.)

A: \_\_\_\_\_

B: \_\_\_\_\_ (I'm not homesick.)

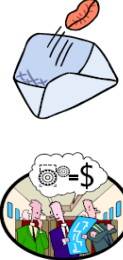

# WH Questions Chart

Who?	What?	Where?	When?	Why?	How?
person people 	thing, idea, event or action 	place 	time 	reason 	manner, way 

Write more examples for each WH question.

1. **Who** is he?

---

2. **What** is this?

---

3. **Where** are you?

---

4. **When** is class?

---

5. **Why** is he scared?

---

6. **How** can we learn English?

---



---



---



---



---

















---



# Feelings Vocabulary

How do you feel?

I feel \_\_\_\_\_.

proud 	angry 
greedy 	excited 
sleepy 	happy 
thirsty 	hungry 
relaxed 	hurt 
confused 	sad 
loving 	worried 





## How does he feel?

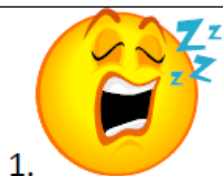

1. How does he feel - sleepy or happy?

He feels \_\_\_\_\_.

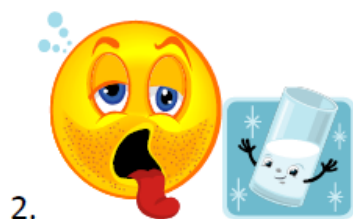

2. How does he feel - hungry or thirsty?

He feels \_\_\_\_\_.



3. How does he feel - confused or sleepy?

He feels \_\_\_\_\_.



## 2-4 USING *HAVE* AND *HAS*

SINGULAR	PLURAL		
(a) <b>I</b> <i>have</i> a pen.	(f) <b>We</b> <i>have</i> pens.	<i>I</i> <i>you</i> <i>we</i> <i>they</i>	
(b) <b>You</b> <i>have</i> a pen.	(g) <b>You</b> <i>have</i> pens.		+ <i>have</i>
(c) <b>She</b> <i>has</i> a pen.	(h) <b>They</b> <i>have</i> pens.		
(d) <b>He</b> <i>has</i> a pen.		<i>she</i> <i>he</i> <i>it</i>	
(e) <b>It</b> <i>has</i> blue ink.			+ <i>has</i>

### □ EXERCISE 9. Sentence practice.

*Directions:* Complete the sentences. Use *have* and *has*.

- We   *have*   grammar books.
- I                      a dictionary.
- Kate                      a blue pen. She                      a blue notebook too.
- You                      a pen in your pocket.
- Bob                      a notebook on his desk.



# Do your Homework on →



- Chapter 1: Exercise 3. page 2
- Ch. 1: Ex 4. page 3
- Ch. 1: Ex 6. page 4
- Ch. 1: Ex 10. page 7
- Ch. 1: Ex 12. page 8
- Ch 1: Ex 15. page 10
- Ch 1: Ex17. page 12
- Ch 1: Ex 25. page 19
- Ch2: Ex 2. page 25 + 26
- Ch 2: Ex 3. page 25 + 26
- Ch 2: Ex 9. page 30



# Contact → If there is “a relevant question”.

**Instructor :**

***Ammar Sultan Al-Ma’ani***

***Lecturer***

***English & American Literature***

***University of North Florida – USA***

\*\*\*\*\*

**Office Hours: 11:30 – 12:30 ( Mon, Tue )**

**3:00 - 4:00 (Sun)**

**Mobile :**

**Office Tel.**

**Email: [aalmaani@kfu.edu.sa](mailto:aalmaani@kfu.edu.sa)**





بِسْمِ اللَّهِ الرَّحْمَنِ الرَّحِيمِ  
بِحَمْدِ اللَّهِ

